



STAND-ALONE PASTE WAX INJECTOR

MPI 11-R2

MPI 11-R2

Stand-Alone Paste Wax Injector

UPGRADE TO PASTE!

- > **Converts your existing injector to MPI's PASTE WAX SYSTEM**
- > **A cost-effective alternative to replacing your entire machine**
- > **Accurately controls all injection parameters for unsurpassed pattern quality**
- > **Can also be used for Liquid & Soluble Wax**

Innovative Features

LIQUID/PASTE WAX RESERVOIR

- One reservoir does it all
- Accurately conditions wax to any viscosity from liquid to paste (fastest cycle times with paste wax), providing consistency from pattern to pattern regardless of input wax temperature
- Capable of rapid temperature changes 1°F in 3 min. (1°C in 6 min.), achieving each dies quickest cycle time

MPI CONTROLS IT ALL

- All injection parameters, that is. Unit controls wax temperature, wax flow, wax pressure, injection cycle time and purge/refill

THREE INJECTION CYLINDER SIZES

- Available with 150, 400, or 1130 cu. in. (2.5l, 6.5l, or 18.5l) injection cylinders

ACCURATE 5-ZONE TEMPERATURE CONTROL

- For maintaining constant, accurate temperature throughout the system



FLEX-HOSE WITH THERMOCOUPLE

- Supplied with 6' (1.8m) heated wax hose (additional lengths available)

FLEX-NOZ® INJECTION NOZZLE

- Flexible injection
- Precise temperature control

X-Y NOZZLE POSITIONER (NOT SHOWN)

- Total alignment 10" (25.4cm) travel for nozzle-to-die alignment (Motor Driven)

UTILIZE YOUR PRESS WHILE UPGRADING TO PASTE WAX INJECTION

- Adaptable to any type of clamping unit with minimum hydraulic specifications of 2000 PSI @ 4 GPM (137.9 bar @ 15.14 lpm)

WAX RESERVOIR LEVEL CONTROL

- For automatic refill of the wax reservoir from a liquid wax source

CUSTOMER SUPPLIES PRESS

MODEL 11R2 SPECIFICATIONS

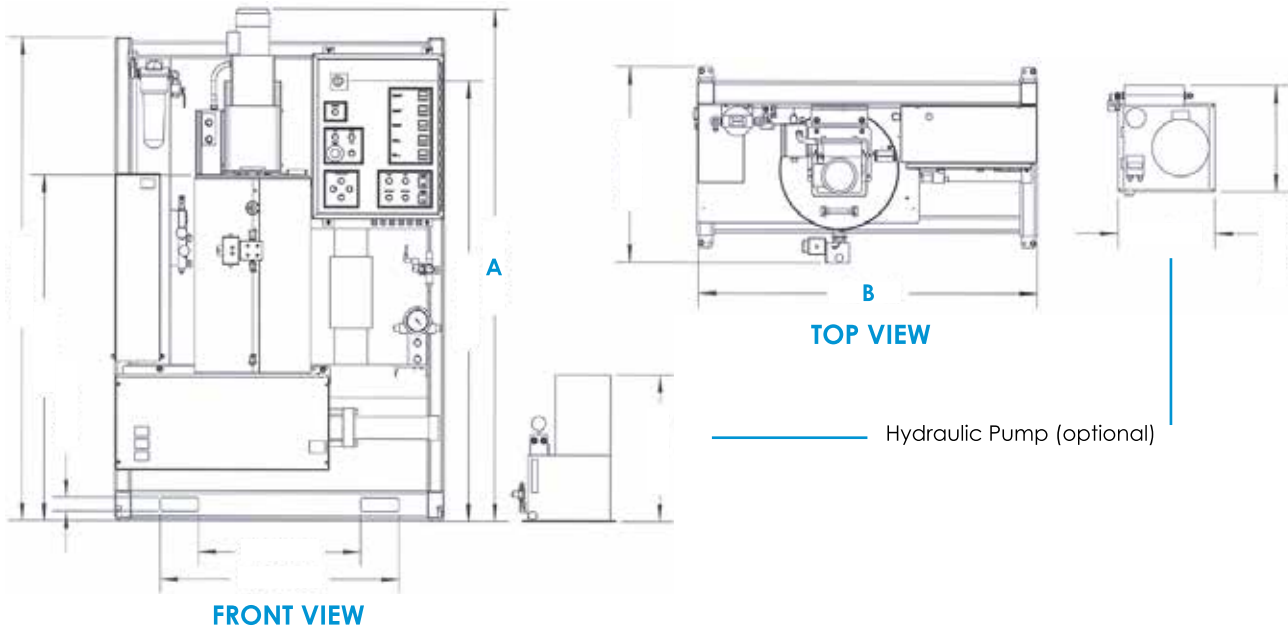

| | US (60HZ) | METRIC (50Hz) |
|--|------------------|-----------------|
| A. Overall Height | 93 in | 2,363 mm |
| B. Overall Width | 60 in | 1,590 mm |
| Wax Reservoir Capacity | 30 gal | 113 l |
| Single Shot Capacity (available with one of three sizes) | 150 cu in | 2.4 l |
| Injection Pressure | 50 - 1000 psi | 3.5 - 70 bar |
| Injection Rate | 0 - 15 cu in/sec | .24 l/sec |
| Injection Time | 0 - 999 sec | |
| Electric Standard | 460V, 60Hz, 3ph | 380V, 50Hz, 3ph |
| Air Requirements | 90 psi | 6.2 bar |
| Machine Weight | 2,000 lb | 908 kg |

Notes: Optional equipment may alter the machines overall dimensions, weight, and power requirements. Contact MPI sales department for additional information. MPI reserves the right to change specifications as required.

LIMITLESS POSSIBILITIES



EXPERIENCE THE DIFFERENCE

MPI is the worldwide leader in wax-room and ceramic core equipment and the acknowledged leader in wax-room innovations. MPI has developed and introduced more systems and products than all its competitors combined and offers wax-room solutions that can't be found anywhere else.

WAX INJECTORS

MPI's wax and ceramic injection machines are the most sophisticated in the industry and generate higher casting yields, more patterns per hour, reduced scrap, and increased productivity. They're also the most reliable in the industry, which means higher system availability, lower maintenance costs, and better performance.

AUTOMATION

MPI is at the forefront of automation, having automated some of the most complex processes in the investment casting industry for well over a decade. MPI's automated injection and assembly cells provide the capability to make and assemble wax patterns from the simplest commercial parts to complex patterns required by the medical and aerospace industries, including single crystal turbine blades. MPI can automate a single process or implement full-scale automation for your facility.



SA55-25-24
C-Frame Wax Injector



SA20-06-06
Automated Pattern Injection Cell

MPI TECHNOLOGY CENTER

MPI is at its best when it can innovate. MPI prides itself at being able to look at problems and then customize solutions that help clients achieve their goals. The MPI Technology Center is a state-of-the-art wax room that allows MPI to do just that. Located at MPI's world headquarters in New York, the Technology Center is a hub of innovation, ingenuity, and problem solving. Customers and suppliers visit this sophisticated facility to discover new ways to solve their unique wax-room challenges and to experience a totally automated facility in full operation.

MPI EXCELS

Most important, return on investment (ROI) is where MPI excels. MPI supports its customers' bottom line with creative, customized products and services that fit their evolving needs. Through collaboration, we innovate, design, build, and integrate solutions that deliver measurable results.

MPI
=
ROI

