

LIMITLESS POSSIBILITIES



EXPERIENCE THE DIFFERENCE

MPI is the worldwide leader in wax-room and ceramic core equipment and the acknowledged leader in wax-room innovations. MPI has developed and introduced more systems and products than all its competitors combined and offers wax-room solutions that can't be found anywhere else.

WAX INJECTORS

MPI's wax and ceramic injection machines are the most sophisticated in the industry and generate higher casting yields, more patterns per hour, reduced scrap, and increased productivity. They're also the most reliable in the industry, which means higher system availability, lower maintenance costs, and better performance.

AUTOMATION

MPI is at the forefront of automation, having automated some of the most complex processes in the investment casting industry for well over a decade. MPI's automated injection and assembly cells provide the capability to make and assemble wax patterns from the simplest commercial parts to complex patterns required by the medical and aerospace industries, including single crystal turbine blades. MPI can automate a single process or implement full-scale automation for your facility.



SA55-25-24
C-Frame Wax Injector



SA20-06-06
Automated Pattern Injection Cell

MPI TECHNOLOGY CENTER

MPI is at its best when it can innovate. MPI prides itself at being able to look at problems and then customize solutions that help clients achieve their goals. The MPI Technology Center is a state-of-the-art wax room that allows MPI to do just that. Located at MPI's world headquarters in New York, the Technology Center is a hub of innovation, ingenuity, and problem solving. Customers and suppliers visit this sophisticated facility to discover new ways to solve their unique wax-room challenges and to experience a totally automated facility in full operation.

MPI EXCELS

Most important, return on investment (ROI) is where MPI excels. MPI supports its customers' bottom line with creative, customized products and services that fit their evolving needs. Through collaboration, we innovate, design, build, and integrate solutions that deliver measurable results.

MPI = ROI



AUTOMATIC HORIZONTAL WAX INJECTOR

MPI 45-12

The innovative, high volume wax injector designed to increase wax pattern quality, quantity, throughput, and ...your bottom line.

The MPI 45 incorporates the latest MPI systems technology in a compact, automated, cost-efficient unit, designed to increase throughput. Everything about this unit saves you time and money. Loaded with features that make it a real performer.

MPI 45-12

Automatic Horizontal Wax Injector

STANDARD MODELS

MPI 45-12 12 ton (10.7 metric tons) 30" (762 mm) daylight
 MPI 45-25 25 ton (22.3 metric tons) 35" (889 mm) daylight

Process Control

All MPI machines are equipped with Smart System Process Controls that provide state-of-the-art process control utilizing user-friendly Windows-based injection control software that features an intuitive touch-screen display. Our Smart System consistently monitors and controls all variables in real time against your pre-established baselines for wax temperature, wax flow, wax pressure, injection time and viscosity, resulting in patterns that are consistent and of the highest quality. This technology eliminates the possibility of accidentally making an out-of-tolerance wax pattern. No one else even comes close.

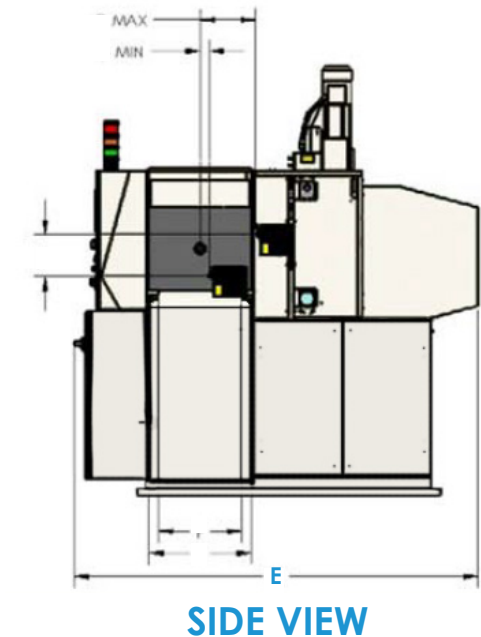
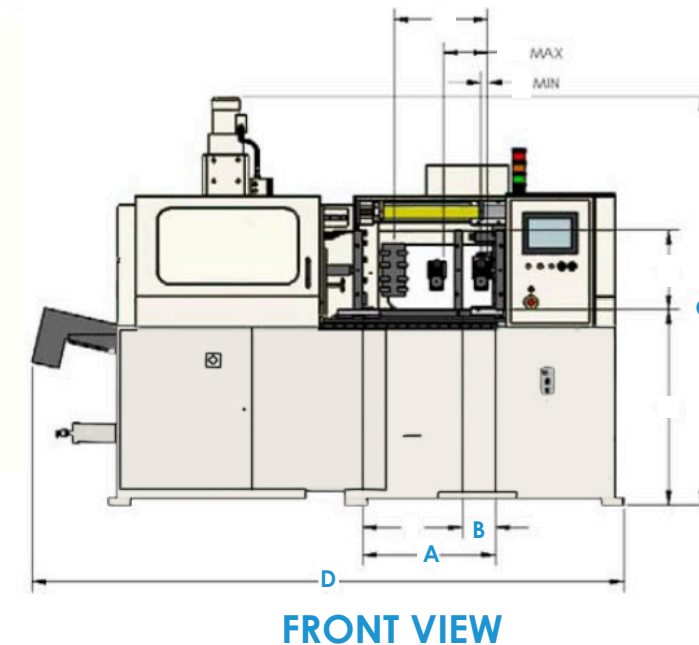
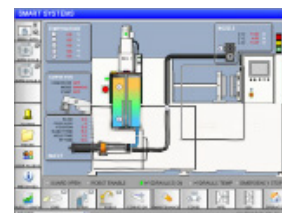

Innovative Features & Options:

PATTERN REMOVAL CONVEYOR

The Model 45 Automatic Injection machine is supplied standard with a conveyor for automatic pattern removal. The pattern is ejected from the tool and dropped into a pool of water where it is allowed to cool before being carried out of the machine frame by the conveyor.



JIB CRANE

The unique combination of Horizontal C-Frame and Jib Crane allow quick, safe changeovers of wax dies by a single operator.



FULL SWEEP HORIZONTAL DIE LUBRICATION SYSTEM

Consistent pattern ejection with no sticking is achieved through a fully adjustable, programmable system controlling spray on/off position, number of nozzles, spray frequency, and die lubrication in both extended or retracted position.

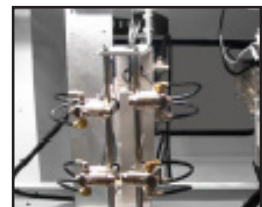

QUICKCHANGE TECHNOLOGY

From Die Clamping to instant uploading of pattern "recipes" the MPI 45 is engineered to minimize transition times and maximize the throughput of quality patterns.

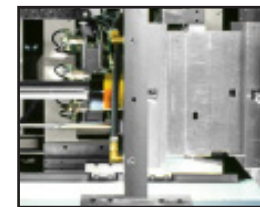

	US (60Hz)	METRIC (50Hz)	US (60Hz)	METRIC (50Hz)
Clamp Force	12 ton	10.7 ton	25 ton	22.3 ton
A. Daylight Maximum	30 in	762 mm	35 in	889 mm
B. Daylight Minimum	5 in	127 mm	5 in	127 mm
C. Overall Height	92 in	2,340 mm	96 in	2,438 mm
D. Overall Width (Includes Conveyor)	133 in	3,380 mm	138 in	3,505 mm
E. Overall Depth	86 in	2,180 mm	92 in	2,336 mm
Wax Reservoir Capacity	30 gal	114 l	30 gal	114 l
Single Shot Capacity	150 cu in	2.5 l	150 cu in	2.5 l
Injection Pressure	50-1,000 psi	3.5-70 bar	50-1,000 psi	3.5-70 bar
Injection Rate	0-15 cu in/sec	0-.2 l/sec	0-15 cu in/sec	0-.2 l/sec
Injection Time	0-999 sec	0-999 sec	0-999 sec	0-999 sec
Electric Standard	480V, 60Hz, 3ph	380V, 50Hz, 3ph	480V, 60Hz, 3ph	380V, 50Hz, 3ph
Air Requirements	80 psi	5.3 bar	80 psi	5.3 bar
Machine Weight	7,500 lbs	3,402 kg	10,000 lbs	4,536 kg

Notes: Optional equipment may alter the machines overall dimensions, weight, and power requirements. The daylight described herein is a nominal dimension. The actual daylight for your machine may be up to 3/8" (9.5mm) less than this dimension. Contact MPI sales department for additional information. We reserve the right to change specifications without notice.

DS-45-12-09-18-20